

Focus Display Solutions, Inc.

---

Add: 162 W Boxelder Place  
Suite 1  
Chandler, AZ 85225

Tel: (480)503-4295

Fax: (866)752-0165

[http: www.FocusLCD.com](http://www.FocusLCD.com)

---

## 1. Description:

MU203 is a color decode IC for FSLCD . It can support 80 segment on LCD. Customer's MCU sending different Color Command to each pixel, which can decode 8 colors's command (Red, Green, Blue , Yellow, Cyan, Purple, Black and Write),and then send data to LCD drivers.

## 2. Features:

- Operating voltage: 5.0V
- Sleep mode
- Display content: "8"+ logos
- Display type: FSLCD
- Display mode: Positive
- Driving method: Static
- 28 Pin SOP package(MU203M) and bare chip(MU203) available

WWW.FocusLCD.com

### 3. Pin Description:

Pin Name	Function	I/O
SDAT	Serial Data input pin with serial transmission	I
GND	Power Ground	ground
VDD	Power Supply	+5V
/RESET	LCM reset pin ,low plus LCM will reset	I
BUSY	Busy Signal	O
/CS	Chip Select , low is chip select	I
SCLK	clock pulse pin with transmission	I
DAT0 -- DAT7	Parallel data0 -- data7	I
P/S	P/S PIN connects with VDD, working on Serial Mode,P/S PIN connects with VSS, working on Parallel Mode	I
TEST	TEST PIN connects with VSS, working under the SELFTEST mode, for aging test of LCM,When it work normally, connecting with VDD	I
OSCO OSCI	Crystal output terminal and input terminal	I/O
DATA	Send data to LCD driver	O
CLK2	Shift the data into the LCD driver	O
CLK1	Latch the data after shift is completed	O
FR	Alternate the LCD driving waveform	O
R G B	Control R G B backlight	O

#### 1. LCM parallel interface pin :

4	3	5	6	7	8	9
VDD	VSS	/RESET	BUSY	/CS	SCLK	DAT0
10	11	12	13	14	15	16
DAT1	DAT2	DAT3	DAT4	DAT5	DAT6	DAT7

#### 2.LCM serial interface pin:

4	3	5	6	7	8	2
VDD	VSS	/RESET	BUSY	/CS	SCLK	SDAT

#### 4. Timing Diagrams:

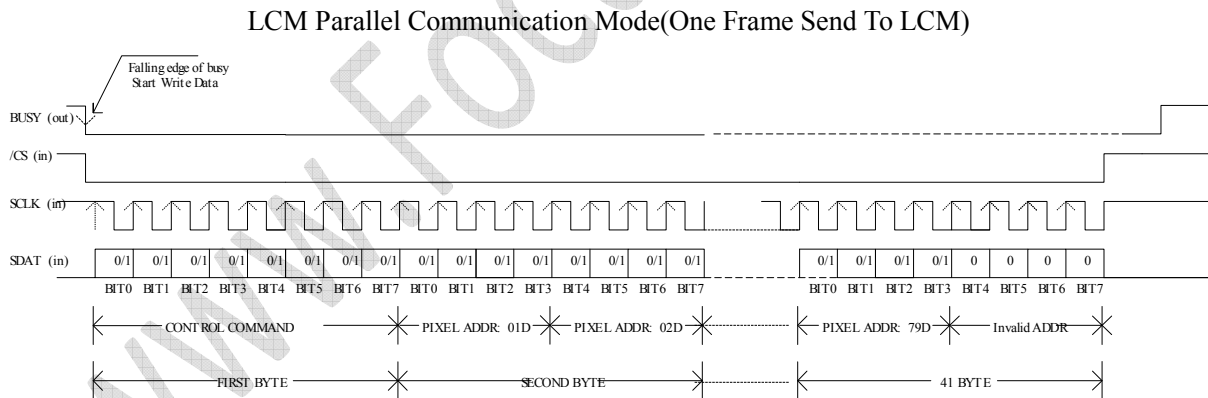
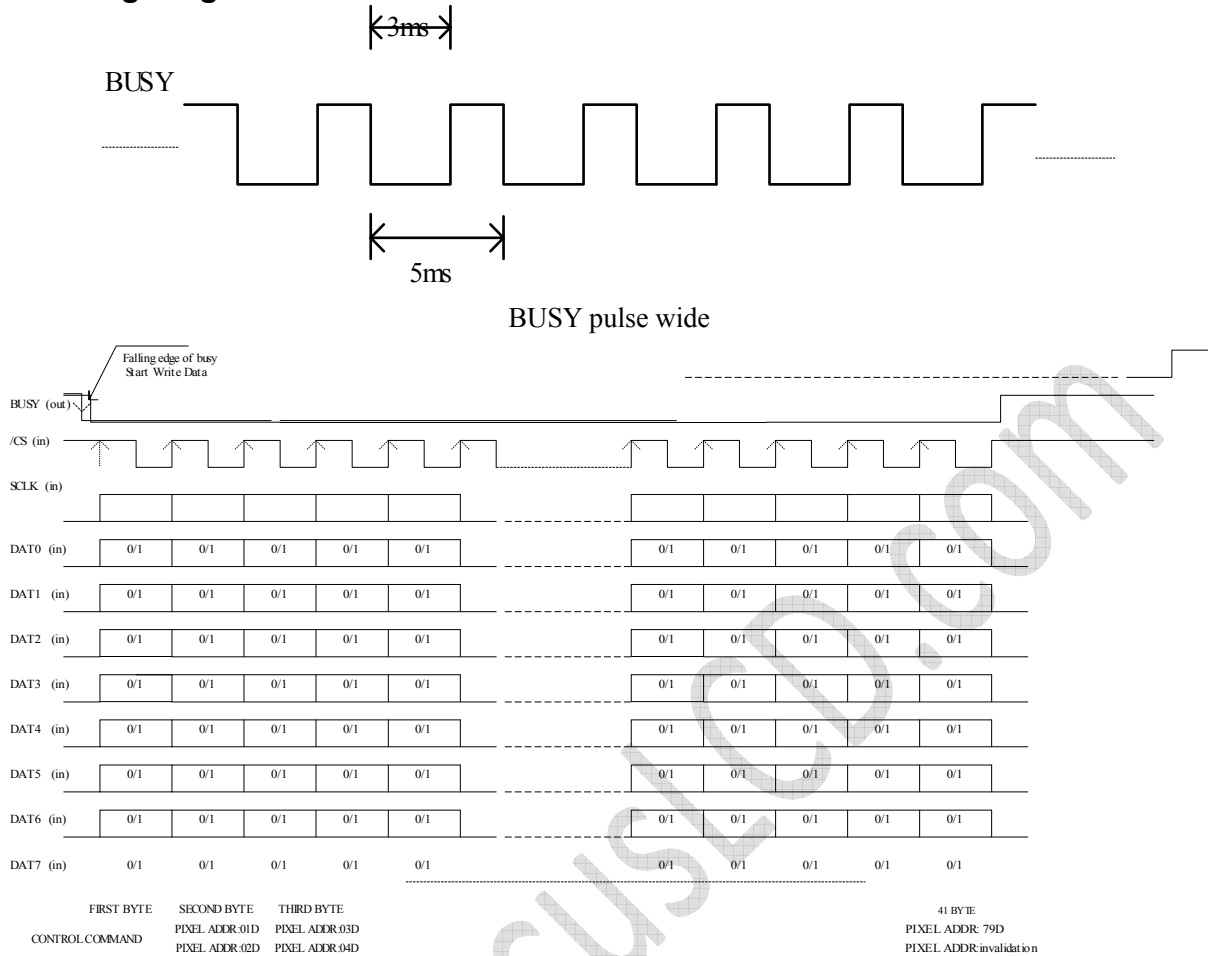

**Note:**

1. When BUSY signal is high, can't write data; falling edge of BUSY, start write data.
2. Clock Rise Edge please send data to LCM, LCM will read data at clock Fall time.
3. If don't send data to LCM ,please keep Sclk high.
4. One frame data must be transported within 3ms when BUSY on low-level, otherwise, screen sparkling occurred after data were transported.
5. Frame period: From the last transferred frame to the next frame need ms at least.















## 5. Control Command:

Bit0	'0': must send '0'		
Bit1	Sleep mode :	'0': sleep off	'1': sleep on
Bit2	Backlight Control Command:	'0': backlight on	'1': backlight off
Bit3	Bright Control:	'0': normally bright	'1': 1/2 bright
Bit4	Color Mode Control :	'0':color mode0(normally color )	'1': color mode1
Bit5	'1': must send '1'		
Bit6	'1': must send '1'		
Bit7	'1': must send '1'		

## 6. Color Command:

One Color Command byte divided into two groups, high nibble [7:4] and low nibble [3:0].

high nibble [7:4] for one Pixel, and low nibble [3:0] for another pixel.

COLOR	BIT3	BIT2	BIT1	BIT0	HEX	Color Mode 0	Color Mode 1
	BIT7	BIT6	BIT5	BIT4			
White	0	0	0	0	0H		
Red	0	0	0	1	1H		
Green	0	0	1	0	2H		
Blue	0	0	1	1	3H		
Yellow	0	1	0	0	4H		
Cyan	0	1	0	1	5H		
Magenta	0	1	1	0	6H		
Black	0	1	1	1	7H		

## 7. Application Circuits:

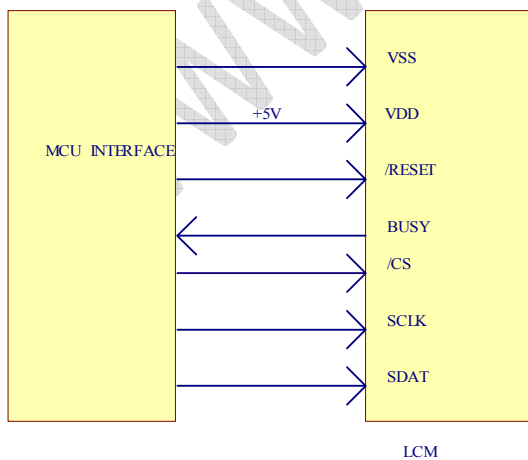

LCM Serial Interface

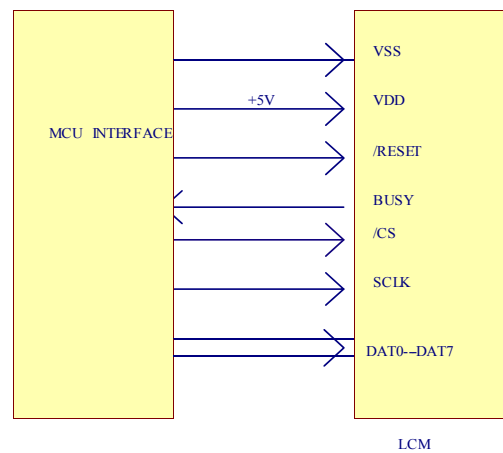

LCM Parallel Interface

## 8. Environmental Characteristics:

Item	Symbol	Condition	Min	Max	Unit
Working Temperature	Twk		-20	80	°C
Storage Temperature	Tstg		-50	120	°C

## 9. Electrical Characteristics:

Parameter	Symbol	Condition	Min	Type	Max	Unit
Input Power voltage	Vdd-GND	25°C	4.5	5.0	5.5	V
Operating Frequency		Vdd=5V	20*(1-50ppm)	20	20*(1+50ppm)	MHz
Input Voltage H level	V <sub>IH</sub>	Vdd=5V	2.0			V
Input Voltage L level	V <sub>IL</sub>				0.8	V
Output Voltage H level	V <sub>OH</sub>		2.4			V
Output Voltage L level	V <sub>OL</sub>				0.4	V

## 10. MU203M Pin Assignment:

Notes: MU203 is bare chip, MU203M is SOP package

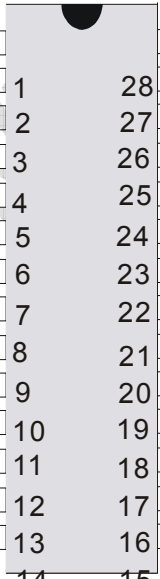

N/C	1	28	/RESET
VDD	2	27	OSCI
N/C	3	26	OSCO
VSS	4	25	DAT7
/CS	5	24	DAT6
BUSY	6	23	DAT5
SCLK	7	22	DAT4
SDAT	8	21	DAT3
P/S	9	20	DAT2
DATA	10	19	DAT1
CLK2	11	18	DAT0
CLK1	12	17	TEST
FR	13	16	B
R	14	15	G

## 11. MU203M package Dimension (28-SOP)

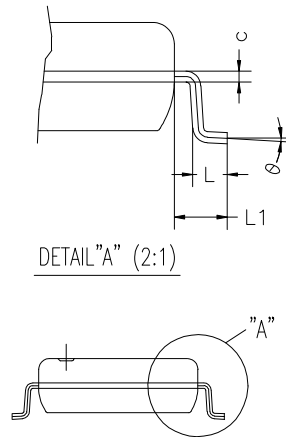
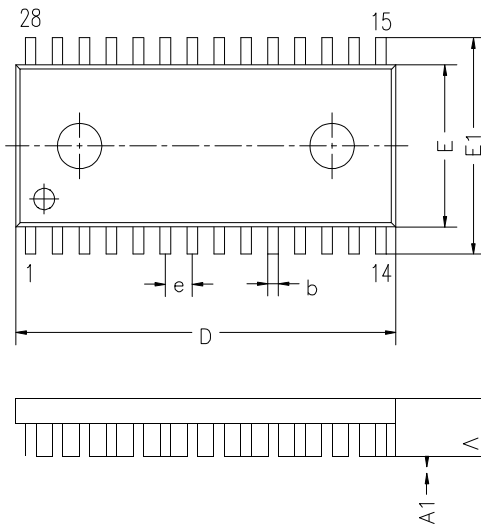

Symbol	Min	Normal	Max
A	2.370	2.500	2.630
A1	0.102	A1	0.300
b	0.350	0.406	0.500
c	0.254(TYP)		
E	7.410	7.500	7.590
E1	10.000	10.325	10.650
D	17.700	17.900	18.100
L	0.678	0.881	1.084
L1	1.194	1.397	1.600
e	1.27(TYP)		
ø	0		8

## 12. MU203 Pad Name and coordinates

Pad No.	Sym.	X	Y
1	N/C	-542.9	710.0
2	VDD	-657.0	557.4
	N/C	-657.0	437.4
4	GND	-657.0	317.4
5	/CS	-657.0	197.4
6	BUSY	-657.0	77.4
7	SCLK	-657.0	-42.6
8	SDAT	-657.0	-162.6
9	P/S	-657.0	-282.6
10	DATA	-657.0	-402.6
11	CLK2	-657.0	-522.6
12	CLK1	-550.0	-710.0
13	FR	-374.6	-710.0
14	R	-197.6	-710.0
	N/C	-22.6	-710.0
15	G	203.4	-710.0
16	B	379.3	-710.0

Pad No.	Sym.	X	Y
17	TEST	555.8	-710.0
18	DAT0	657.3	-544.9
19	DAT1	657.3	-424.9
20	DAT2	657.3	-304.9
21	DAT3	657.3	-184.9
22	DAT4	657.3	-64.9
23	DAT5	657.3	55.1
24	DAT6	657.3	175.3
25	DAT7	657.3	295.3
26	OSCO	657.3	415.3
27	OSCI	657.3	535.3
28	RESET	573.7	710.0
	N/C	384.4	710.0
	N/C	208.4	710.0
	N/C	32.0	710.0
	N/C	-144.0	710.0
	N/C	-370.0	710.0

### 13. MU203 Pad Arrangement

Chip Size : 1580  $\mu\text{m}$  x 1720  $\mu\text{m}$

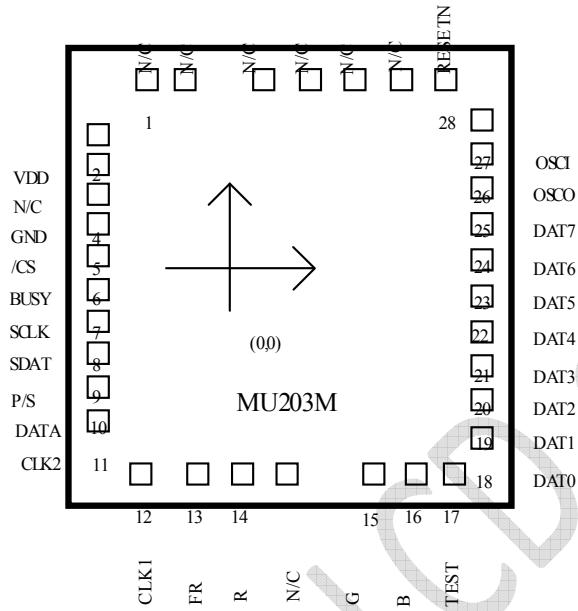

This IC substrate should be float.